

PART III. MARKINGS

A. GENERAL PRINCIPLES

3A-1 Functions and Limitations

Markings have definite and important functions to perform in a proper scheme of traffic control. In some cases, they are used to supplement the regulations or warnings of other devices such as traffic signs or signals. In other instances, they are used alone and produce results that cannot be obtained by the use of any other device. In such cases they serve as a very effective means of conveying certain regulations and warnings that could not otherwise be made clearly understandable.

Pavement markings have definite limitations. They are obliterated by snow, may not be clearly visible when wet, and may not be very durable when subjected to heavy traffic. In spite of these limitations, they have the advantage, under favorable conditions, of conveying warnings or information to the driver without diverting his attention from the roadway.

3A-2 Standardization of Application

Each standard marking shall be used only to convey the meaning prescribed for it in this Manual. Before any new highway, surfaced detour, or temporary route is opened to traffic, all necessary markings should be in place.

Markings no longer applicable which may create confusion in the mind of the motorist shall be removed or obliterated as soon as practicable. Other markings required by road conditions or restrictions should be removed or obliterated when those conditions cease to exist or the restrictions are withdrawn. Markings which must be visible at night shall be reflectorized unless ambient illumination assures adequate visibility. All markings on Interstate highways shall be reflectorized.

Of growing importance is the tendency of traffic authorities to accommodate variable traffic conditions with different types of operation. For this purpose, signs and signals with the ability to display variable messages have been developed. The use of variable messages in the field of markings, however, has been somewhat more limited and confined to the manual placement of flexible cones and posts, and to a few mechanically-operated devices. It is to be expected that the future will bring forth new, practical methods of conveying variable messages by means of markings. When such need and opportunity occur, extreme care should be used to adhere to the principles set forth in this Manual.

3A-3 Materials

The most common method of placing pavement, curb, and object markings is by means of paint; however, a wide variety of other suitable marking materials including raised pavement markers is available. Materials used should provide the specified color throughout their useful life.

III-9(c)
Rev. 4

Marking material used in the vicinity of pedestrian activity should not present tripping or excessive slipping hazards.

3A-4 Colors

Pavement markings shall be yellow, white, or red in color.

The use of black is permitted in combination with the above colors where the pavement itself does not provide sufficient contrast. This use of black does not establish it as a standard pavement marking color but only as a means of achieving contrast on light-colored pavements.

The colors for pavement marking shall conform to the standard highway colors.

3A-5 General Principles-Longitudinal Pavement Markings

Longitudinal pavement markings shall conform to the following basic concepts:

1. Yellow lines delineate the separation of traffic flows in opposing directions or mark the left edge of the pavement of divided highways and one-way roads.

2. White lines delineate the separation of traffic flows in the same direction or mark the right edge of the pavement.

3. Red markings delineate roadways that shall not be entered or used by the viewer of those markings.

4. Broken lines are permissive in character.

5. Solid lines are restrictive in character.

6. Width of line indicates the degree of emphasis.

7. Double lines indicate maximum restrictions.

8. Markings which must be visible at night shall be reflectorized unless ambient illumination assures adequate visibility.

9. Raised pavement markers may serve as position guides for, may supplement, or in some cases may be substituted for other types of markings.

III-9(c)
Rev. 4

3A-6 Widths and Patterns of Longitudinal Lines

The widths and patterns of longitudinal lines shall be as follows:

1. A normal width line is 4" to 6" wide.

2. A wide line is at least twice the width of a normal line.

3. A double line consists of two normal width lines separated by a discernible space.

4. A broken line is formed by segments and gaps, usually in the ratio of 1:3. On rural highways, a recommended standard is 10 foot segments and 30 foot gaps. Other dimensions in this ratio may be used as best suit traffic speeds and need for delineation.

5. A dotted line is formed by short segments, normally two feet in length, and gaps, normally four feet or longer.

3A-7 Types of Longitudinal Lines

The following examples illustrate the application of the principles and standards set forth in sections 3A-4 to 3A-6:

1. A normal, broken white line is used to delineate the edge of a travel path where travel is permitted in the same direction on both sides of the line. Its most frequent application is as a lane line of a multi-lane roadway.

2. A normal, broken yellow line is used to delineate the left edge of a travel path where travel on the other side of the line is in the opposite direction. A frequent application is as a center line of a two-lane, two-way roadway where overtaking and passing is permitted.

3. A normal, solid white line is used to delineate the edge of a travel path where travel in the same direction is permitted on both sides of the line but crossing the line is discouraged and to mark the right edge of the pavement. A frequent application is as a lane line approaching an intersection. A wide solid white line is used for emphasis where the crossing requires unusual care. It is frequently used as a line to delineate left or right turn lanes.

4. A double solid white line is used to delineate a travel path where travel in the same direction is permitted on both sides of the line, but crossing the line is prohibited. It is frequently used as a channelizing line in advance of obstructions which may be passed on either side but not encroached upon.

5. A double line consisting of a normal, broken yellow line and a normal, solid yellow line delineates a separation between travel paths in opposite directions where overtaking and passing is permitted with care for traffic adjacent to the broken line and is prohibited for traffic adjacent to the solid line. This is a one direction, no-passing marking. It is used on two-way, two- and three-lane roadways to regulate passing. It is also used to delineate the edges of a lane in which travel in either direction is permitted (but only as part of a left turn maneuver). In the latter application, the markings are to be placed with the solid lines on the outside and the dashed lines to the inside of the lane. Traffic adjacent to the solid line may cross this marking with care only as part of a left-turn maneuver.

6. A double line consisting of two normal solid yellow lines delineates the separation between travel paths in opposite directions where overtaking and passing is prohibited in both directions. This is a two-

direction, no-passing marking. Crossing this marking with care is permitted only as part of a left-turn maneuver. It is frequently used as a channelizing line in advance of an obstruction which must be passed on the right and to form a channelizing island separating traffic in counter directions.

7. A double, normal, broken yellow line delineates the edge of a lane in which the direction of travel is changed from time to time in such a way that the line serves as the centerline of the roadway during some period. Its use is for a reversible lane.

8. A normal dotted line is used to delineate the extension of a line through an intersection or interchange area. It shall be the same color as the line it extends.

9. A solid yellow line delineates the left edge of a travel path to indicate a restriction against passing on the left or delineates the left edge of each roadway of divided streets or highways, one-way roadways, and ramps in the direction of travel.

3A-8 Transverse Markings

Transverse markings, which include shoulder markings, word and symbol markings, stop lines, crosswalk lines, speed measurement markings, parking space markings and others shall be white except that:

1. Transverse median markings shall be yellow (sec. 3B-10).

2. Markings visible only to traffic proceeding in the wrong direction on a one-way roadway may be red

Because of the low approach angle at which pavement markings are viewed, it is necessary that transverse lines be proportioned to give visibility equal to that of longitudinal lines. Pavement marking letters, numerals, and symbols shall be in accordance with the Standard Alphabets for Highway Signs and Pavement Markings.*

3A-9 Curb Markings

Curb markings fall into two categories: roadway delineation (sec. 3D-3) and parking regulations (sec. 3B-21).

III-9(c)
Rev. 4

3A-10 Raised Pavement Markers, ReflectORIZED and Non-ReflectORIZED

Raised pavement markers may be used as positioning guides, or to supplement, or in some cases to substitute for other types of markings. The color of raised pavement markers shall conform to the color of the marking for which they serve as a positioning guide, or for which they supplement, or substitute.

III-9(c)
Rev. 4

*Available from the Federal Highway Administration (HTO-20), Washington, D.C. 20590.

Retroflective raised pavement markers are generally preferable for most applications. Non-retroflective raised pavement markers should not be used alone, without supplemental retroflective markers, as a substitute for other types of pavement markings.

Retroreflectorized raised pavement markers normally are available in mono-directional and bi-directional configurations with white and yellow retroflective elements. Other colors, and combinations of colors may be used for special purposes. Use should be made of the mono- and bi-directional characteristics available to maximize the information given to the motorist, to minimize wrong information and to avoid confusion resulting from visibility of markers which do not apply to the motorist.

The spacing of raised pavement markers used to supplement or substitute for other types of longitudinal markings should be chosen in relationship to the pattern of broken lines being supplemented or substituted for, using a value of "N" equal to the length of one line segment plus one gap.

Applications of raised pavement markers are described in Sec. 3B-14, 3B-15 and 3B-16. These applications are not intended to preclude the use of metallic markers or inserts, less than 1" high with no other coloring or retroreflectorization on the pavement when installed primarily to aid in repainting or installation of other types of markings. Such devices are not classified as raised pavement markers.

III-9(c)
Rev. 4

B. APPLICATIONS OF PAVEMENT AND CURB MARKINGS

3B-1 Center Lines

A center line separates traffic traveling in opposite directions. It need not be at the geometrical center of the pavement. Centerlines provide important guidance to motorists and should be used on most paved roads. On roads where a continuous centerline is not used, short sections may be used to control the position of traffic at specific locations, such as around curves, over hills, and on approaches to intersections, railroad crossings, and bridges.

The center line markings on two-lane, two-way highways shall be either:

1. a normal, broken yellow line where passing is permitted (#2, sec. 3A-7), or
2. a double line consisting of a normal broken yellow line and a normal, solid yellow line where passing is permitted in one direction (#5, sec. 3A-7), or
3. a double line consisting of two normal solid yellow lines where passing is prohibited in both directions (#6, sec. 3A-7).

The center line on undivided highways where four or more lanes are always available, is usually a double solid yellow line.

On three-lane rural highways, two lanes should be designated for traffic in one direction and marked as illustrated in figures 3-2a and 3-2b (page 3B-3).

Center lines are recommended on paved highways under the following conditions:

1. In rural districts on two-lane pavements 16' or more in width with prevailing speeds of greater than 35 MPH.
2. In residence or business districts on all through highways, and on other highways where there are significant traffic volumes.
3. On all undivided pavements of four or more lanes.
4. At other locations where an engineering study indicates a need for them.

Applications of center lines are shown in various illustrations herein, particularly figures 3-1, 3-2, 3-3, 3-4, and 3-5.

3B-2 Lane Lines

Lane lines separate lanes of traffic traveling in the same direction. They shall be used on all Interstate highways, and should be used:

1. On all other multi-lane highways.

2. At congested locations where the roadway will accommodate more lanes of traffic than would be the case without the use of lane lines.

Lane lines are usually normal broken white lines which permit lane changing with care.

A normal solid white line may be used as the lane line in critical areas where it is advisable to discourage lane changing. Typical locations for such applications are tunnels or bridges having width restrictions and interchange areas where lane changing disrupts traffic flow.

A solid white line may be used to separate through-traffic lanes from special secondary lanes, such as uphill truck lanes, left-or right-turn lanes and transit bus lanes.

A double solid white line shall be used when lane changing is prohibited.

Applications of lane lines are illustrated in figures 3-1, 3-2, 3-4, 3-5, and 3-6.

3B-3 No-Passing Zone Markings

Where center lines are installed, no-passing zones shall be established at vertical and horizontal curves and elsewhere on two- and three-lane highways where an engineering study indicates passing must be prohibited because of inadequate sight distances or other special conditions. Specific reference is made to section 11-307 UVC Revised 1968.

A no-passing zone shall be marked by either a one direction, no-passing marking (#5, sec. 3A-7) or a two direction, no-passing marking (#6, sec. 3A-7) as illustrated in figure 3-2b.

3B-4 Application of No-Passing Zone Markings

On a two-or three-lane highway, the no-passing marking shall be parallel to and extended along the center line throughout the no-passing zone.

On a three-lane highway where the single lane is being moved from one side of the road to the opposite side, a no-passing buffer zone shall be provided by transitioning the centerline markings diagonally across the center lane to the beginning of the no-passing buffer zone, and thence along this location to the end of the buffer zone (fig. 3-7a). An alternate method of marking this condition is illustrated in figure 3-7b. The markings shall extend across the center lane on a diagonal for a distance (taper length) computed by the formula $L = WS$ for all roadways having a posted speed of 45 m.p.h. or greater. For urban, residential, and other streets having posted speeds of 40 m.p.h. or less, taper length should be computed by the formula $L = WS^2/60$. Under both formulas, L equals the taper length in feet, W the width of the center lane in feet, and S the off-peak 85 percentile speed in miles per hour.

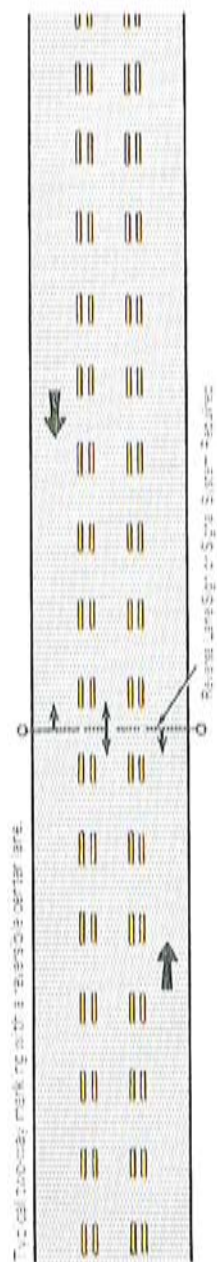

Figure 3-1. Typical reversible lane marking application.

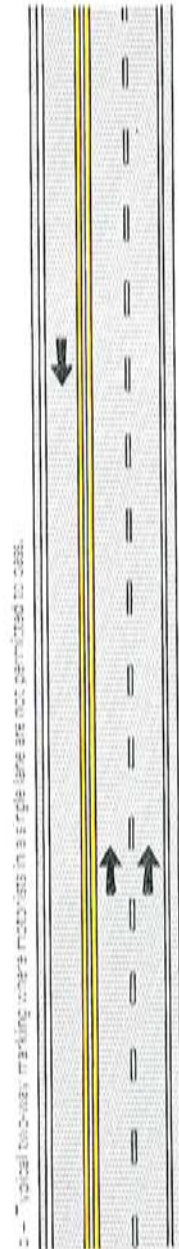
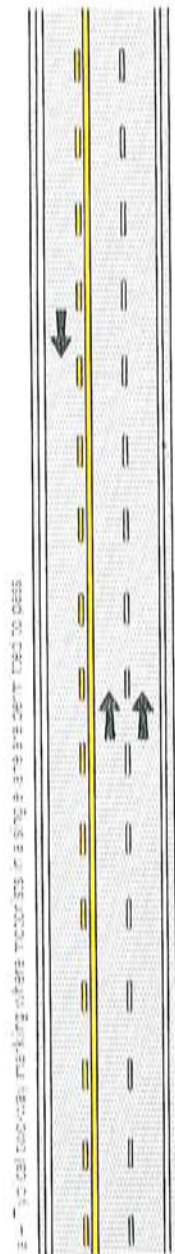
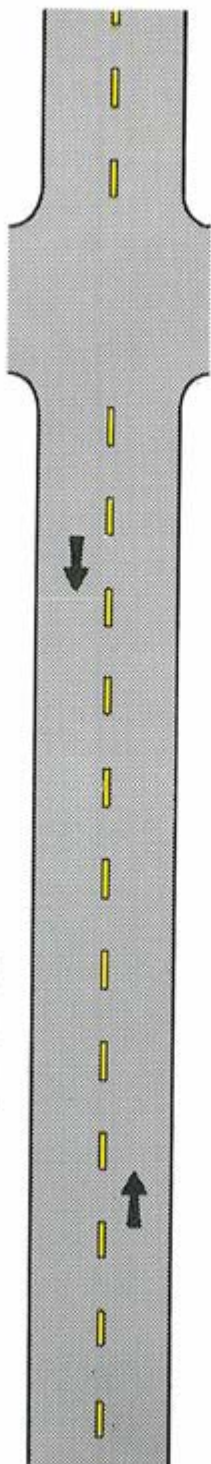

Figure 3-2. Typical 3-lane, two-way marking applications.

a — Typical two-lane, two-way marking with passing permitted.



b — Typical two-lane, two-way marking with passing prohibited zones.

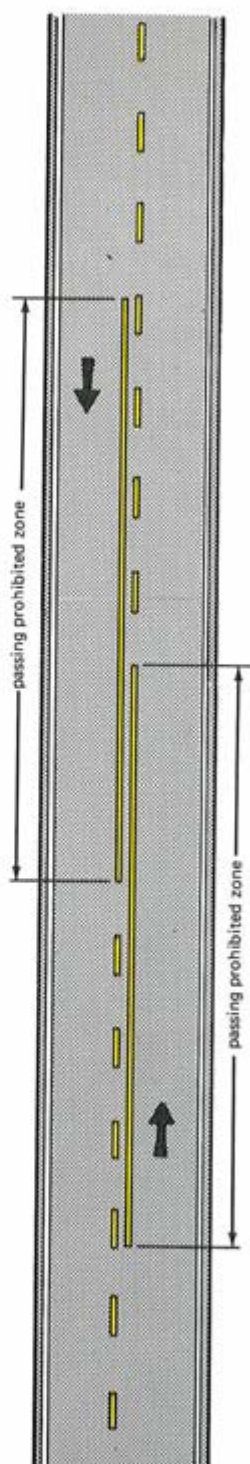
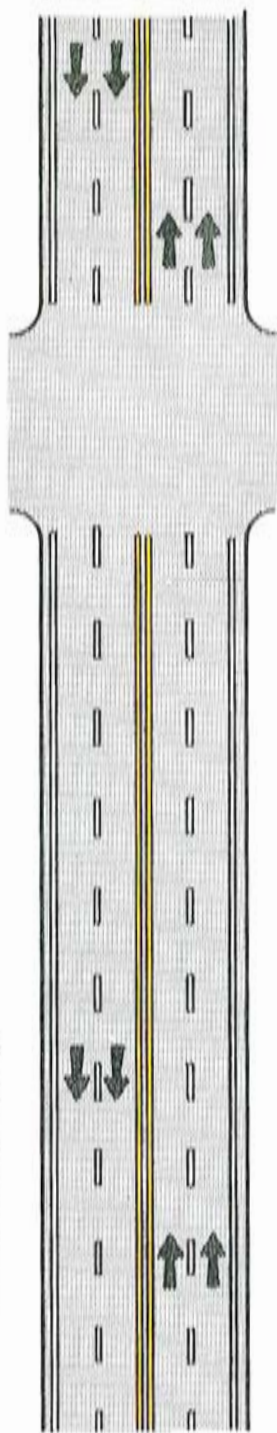

Figure 3-3. Typical 2-lane, two-way marking applications.

a - Typical multi-lane, two-way marking.



b - Typical multi-lane, two way marking with single lane left turn channelization.

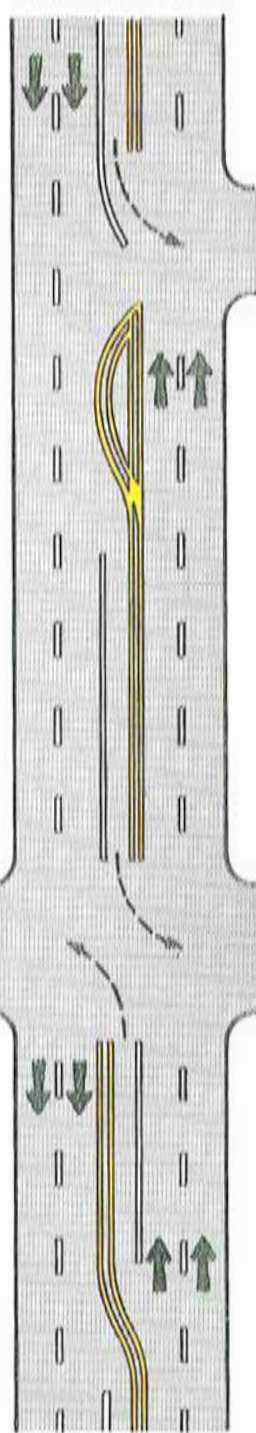
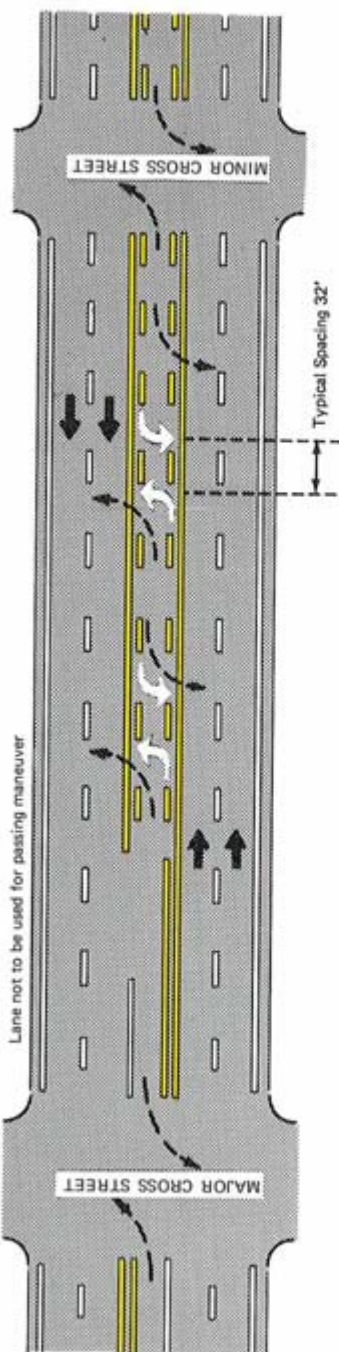

Figure 3-4. Typical multi-lane, two-way marking applications.

a - Typical multi-lane, two-way marking with single lane, two-way left turn channelization.

Lane not to be used for passing maneuver



b - Typical multi-lane, two-way marking with restricted lanes.

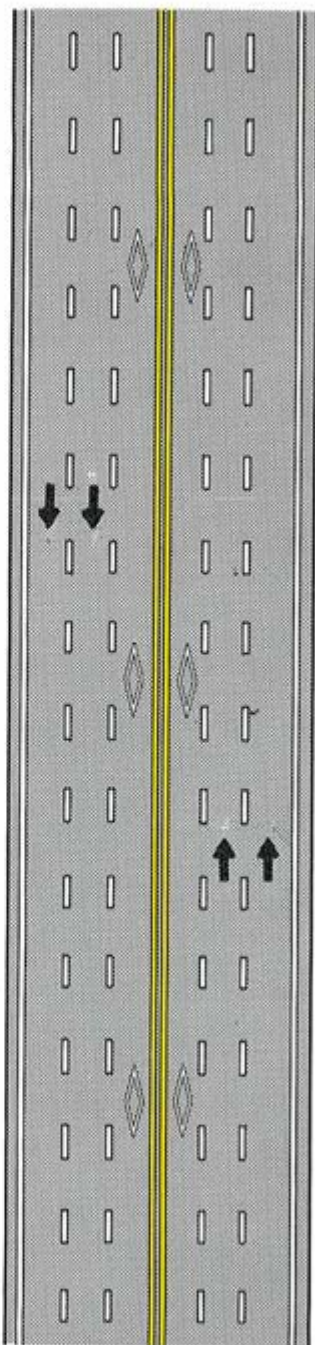

Figure 3-5. Typical multilane, two-way marking applications.

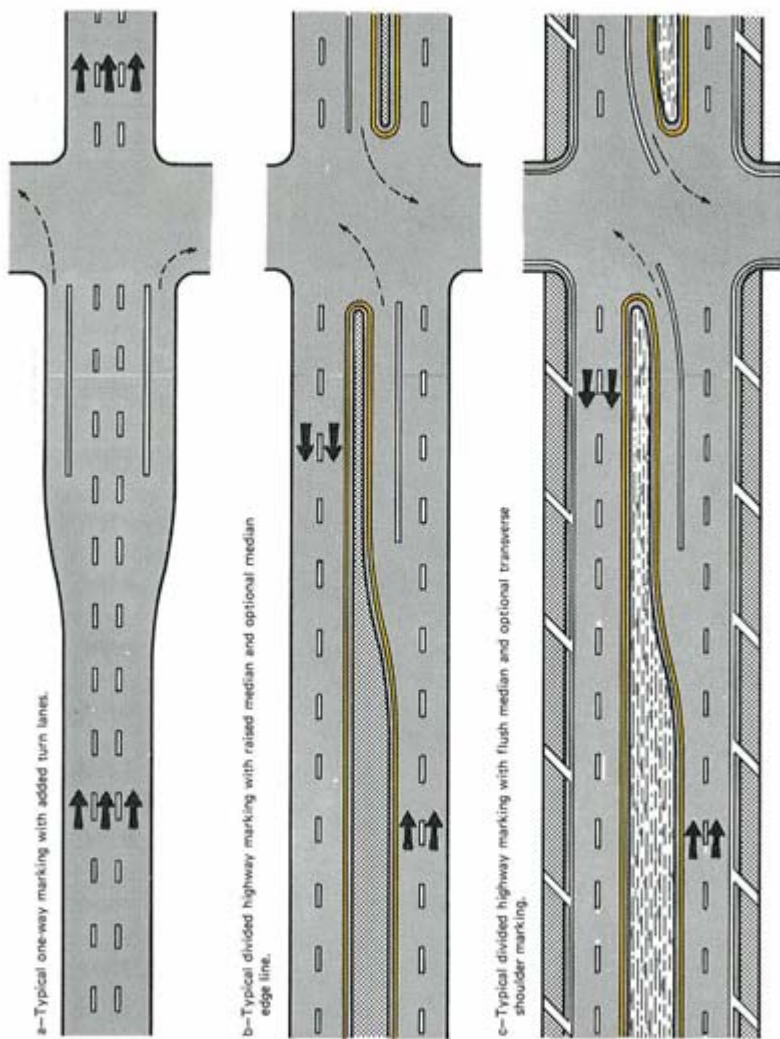

Figure 3-6. Typical one-way and divided highway marking applications.

In addition to the pavement markings here prescribed, no-passing zone signs (secs. 2B-21, 2B-22 and 2C-38) may be used to emphasize the existence and extent of a no-passing zone.

Where the distance between successive no-passing zones is less than 400 feet, the appropriate no-passing marking (one direction or two direction) should connect the zones.

The no-passing marking is also used on two-way roadways at pavement width transitions (sec. 3B-8) and on approaches to obstructions which must be passed on the right (sec. 3B-13). It may also be used on approaches to railroad grade crossings and other locations where passing should be prohibited.

3B-5 Warrants for No-Passing Zones at Curves

A no-passing zone at a horizontal or vertical curve is warranted where the sight distance, as defined below, is less than the minimum necessary for safe passing at the prevailing speed of traffic. Passing sight distance on a vertical curve is the distance at which an object 3.50 feet above the pavement surface can just be seen from a point 3.50 feet above the pavement (fig. 3-8a). Similarly, passing sight distance on a horizontal curve is the distance measured along the center line (or right hand lane line of a three-lane highway) between two points 3.50 feet above the pavement on a line tangent to the embankment or other obstruction that cuts off the view on the inside of the curve (fig. 3-8b). Where center lines are installed and a curve warrants a no-passing zone, it should be so marked where the sight distance is equal to or less than that listed below for the prevailing off-peak 85 percentile speed:

III-4 (c)
Rev. 3

85 Percentile Speed (MPH)	Minimum Passing Sight Distance (Feet)
30	500
40	600
50	800
60	1000
70	1200

The beginning of a no-passing zone (point "a," fig. 3-8) is that point at which the sight distance first becomes less than that specified in the above table. The end of the zone (point "b") is that point at which the sight distance again becomes greater than the minimum specified.

3B-6 Pavement Edge Lines

Pavement edge line markings provide an edge of pavement guide for drivers. They have a unique value as a visual reference for the guidance of drivers during adverse weather and visibility conditions. They also may be used where edge delineation is desirable to reduce driving on paved

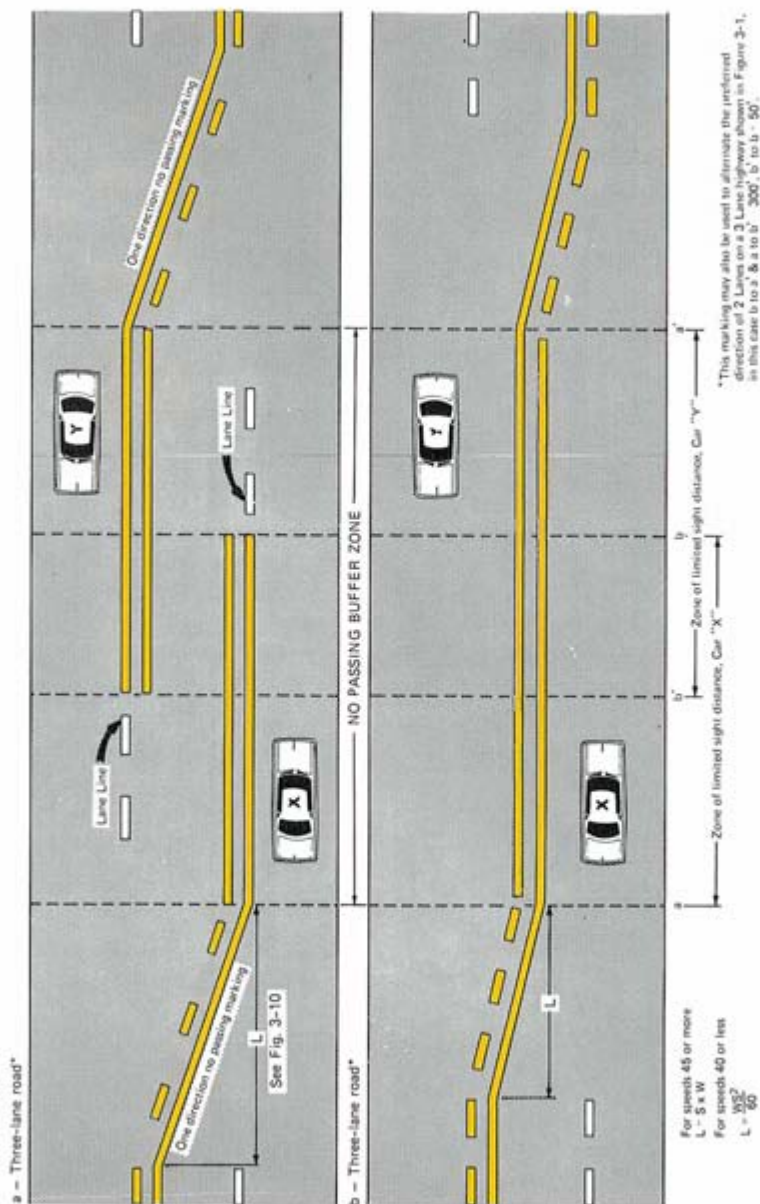

Figure 3-7. Standard 3-lane, two-way pavement marking for alternating preferred direction of two lanes.

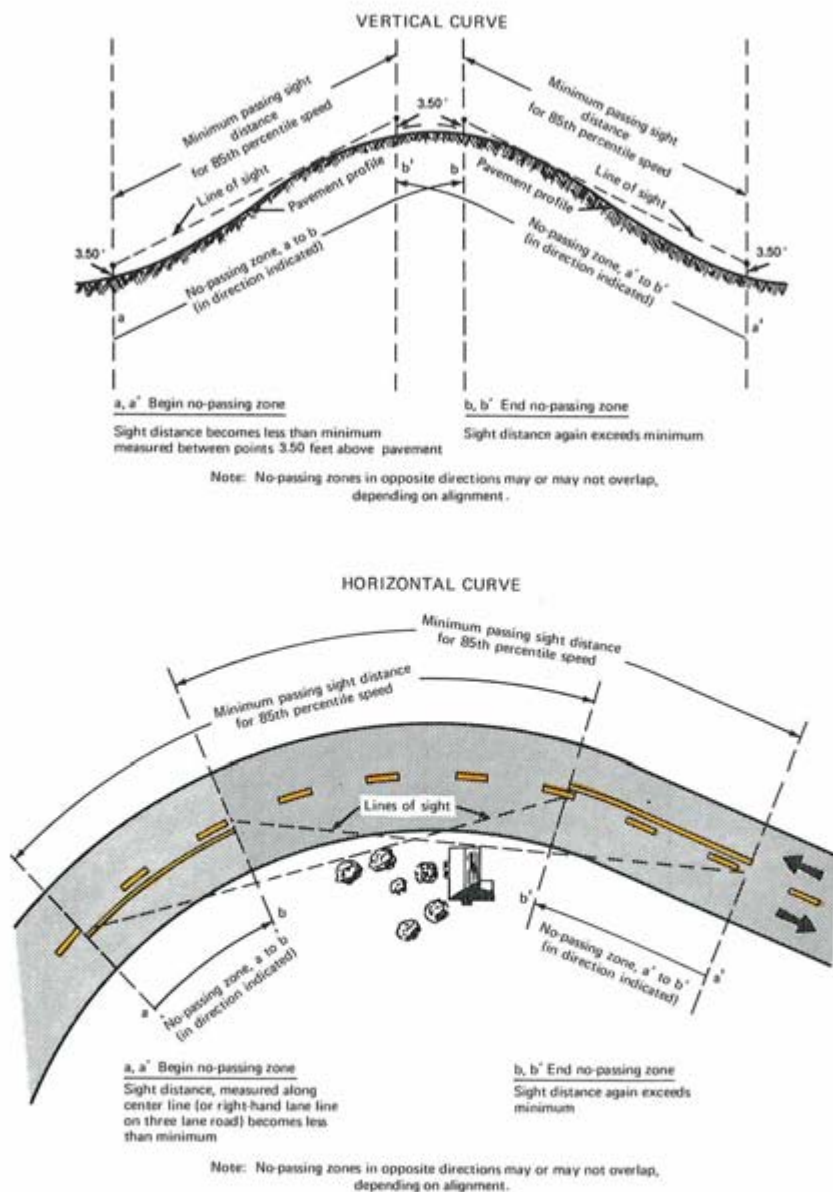

Figure 3-8. Method of locating and determining the limits of no-passing zones at vertical and horizontal curves.

shoulders or refuge areas of lesser structural strength than adjacent pavement. Edge lines shall not be continued through intersections and should not be broken for driveways.

Edge lines shall be provided on all Interstate highways, on rural multilane divided highways, and may be used on other classes of roads. The lines shall be white except that on the left edge of each roadway of divided streets and highways, and one-way roadways in the direction of travel, they shall be yellow.

III-6 (c)
Rev. 1

3B-7 Pavement Marking Extensions Through Intersections or Interchanges

Where road design or reduced visibility conditions make it desirable to provide control or to guide vehicles through an interchange or intersection, (such as at offset, skewed, complex multi-legged intersections or where multiple turn lanes are used) a dotted line may be used to extend markings as necessary through the interchange or intersection area (figs. 3-9a, 3-11). Where a greater degree of restriction is required, solid lane lines or channelizing lines may be continued through intersections. A frequent use for the channelizing line is to separate turning movements (figs. 3-9b, 3-9c).

3B-8 Lane Reduction Transitions

Where pavement markings are used, lane reduction markings shall be used to guide traffic at points where the pavement width changes to a lesser number of through lanes. No-passing markings shall be used to prohibit passing in the direction of the convergence, throughout the transition area. The length of transition (taper length) for a lane reduction should be computed by the formula $L = WS$ for freeways, expressways, and all other roadways having a posted speed of 45 m.p.h. or greater. Formula $L = WS^2 / 60$ should be used to compute taper length on urban, residential, and other streets where the posted speeds are 40 m.p.h. or less. Under both formulas, L equals the taper length in feet, W the offset distance in feet, and S the off-peak 85 percentile speed in miles per hour. On new construction, where no 85 percentile speed is established, the design speed may be used.

A number of situations are possible, as illustrated in figure 3-10, depending on which lanes must be offset or terminated and the amount of offset. One or more lane lines must be connected in such a way as to merge traffic into the reduced number of lanes.

Lane lines should be discontinued one-quarter of the distance between the Pavement Width Transition sign (sec. 2C-19) and the point of convergence. Edge lines should be installed from the location of the warning sign, past the beginning of the narrower roadway (fig. 3-10).

Pavement markings at pavement-width transitions supplement the standard signs.

a—Typical pavement marking with offset lane lines continued through the intersection and optional crosswalk lines and stop limit lines.

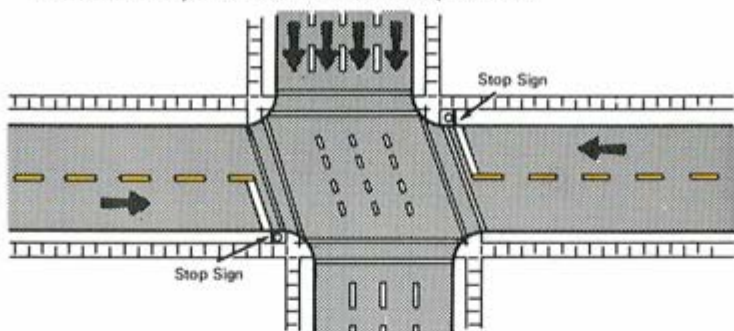

b—Typical pavement marking with optional double turn lane lines, pavement messages, crosswalk lines, and stop limit lines.

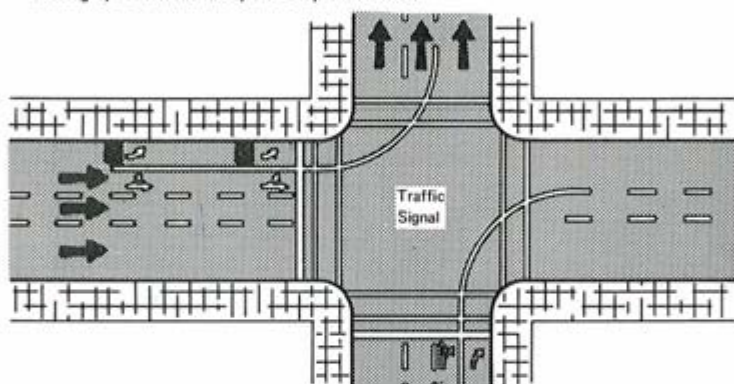

c—Typical pavement marking with optional turn lane lines, crosswalk lines, and stop limit lines.

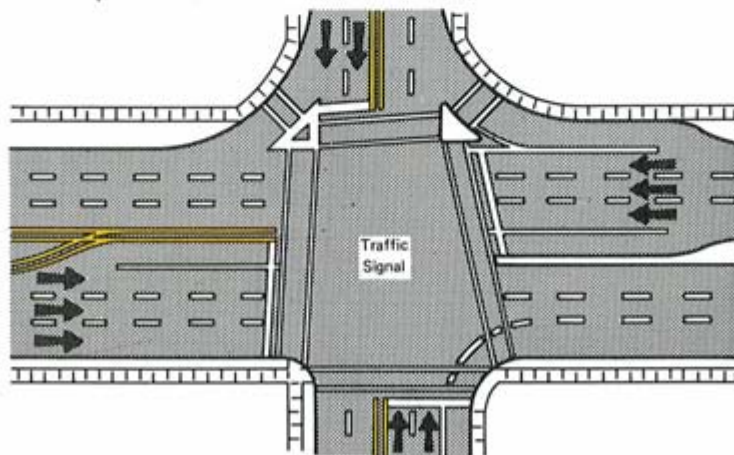
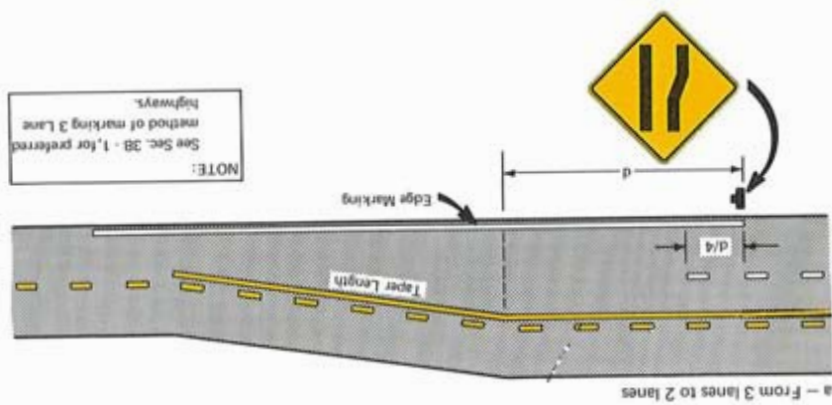
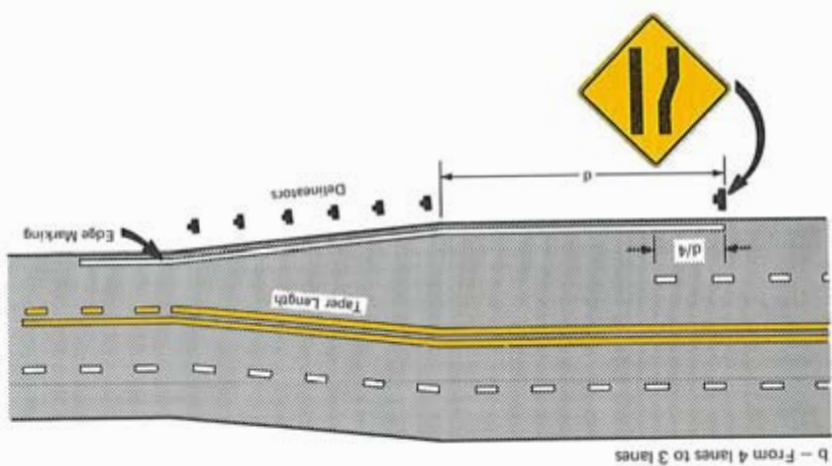
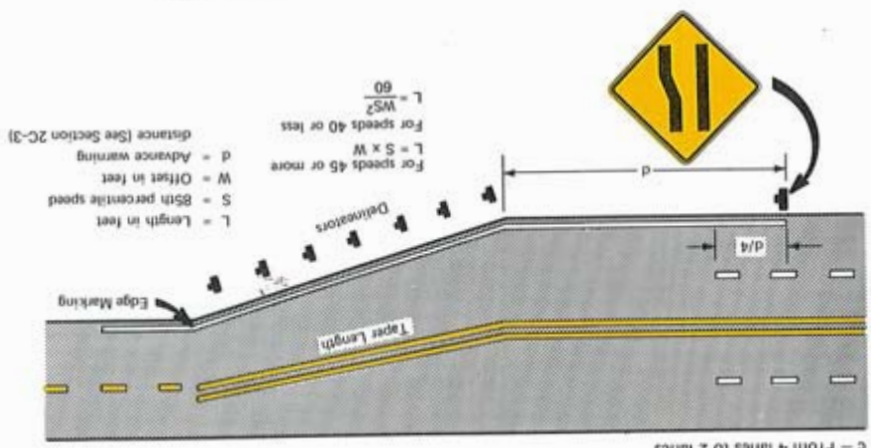

Figure 3-9. Typical pavement marking applications.

Figure 3-10. Typical lane reduction transition markings and signs.



3B-9 Channelizing Line

The channelizing line shall be a wide or double solid white line.

The channelizing line may be used to form traffic islands where travel in the same direction is permitted on both sides. Other markings in the island area such as crosshatching shall be white.

Typical examples of channelizing line applications are shown in figures 3-9, 3-11, 3-12 and 3-13.

3B-10 Median Islands Formed by Pavement Markings

Two double solid yellow lines shall be used to form continuous median islands where these islands separate travel in opposite directions. Other markings in the median island area such as crosshatching shall be yellow (sec. 3A-8).

3B-11 Marking of Interchange Ramps

Channelizing lines at exit ramps provide a neutral area which reduces the probability of collision with the curb nose and also directs exiting traffic at the proper angle for smooth divergence into the ramp (fig. 3-11). The channelizing line promotes safe and efficient merging with the through traffic at entrance ramps (fig. 3-12).

For exit ramps, channelizing lines shall be placed along both sides of the neutral area between the main roadway and the exit ramp lane. With a parallel deceleration lane, a lane line shall be extended from the beginning of the channelizing line upstream for a distance of approximately one-half the length of the full width deceleration lane. White transverse markings may be placed in the neutral area for special emphasis.

For entrance ramps, a channelizing line should be placed along the side of the neutral area adjacent to the ramp lane. With a parallel acceleration lane, a lane line should be extended from the end of the channelizing line for a distance approximately one-half the length of the full width acceleration lane. With a tapered acceleration lane, a lane line may be placed to extend the channelizing line, but not beyond a point where the tapered lane meets the near side of the through traffic lane. Pavement marking arrow usage for Wrong-Way traffic is included in Section 2E-41.

In advance of lane drops at off ramps a special marking pattern may be used to distinguish the lane drop situation from a normal exiting ramp or an auxiliary lane. A typical special marking for lane drops consists of 8-inch wide by 3-foot long white stripes separated by 12-foot gaps. If used, this special marking should begin ½ mile in advance of the theoretical gore point. Where last minute lane changes may cause conflicts, an 8-inch wide solid white channelizing line may extend approximately 300 feet upstream from the theoretical gore point.

III-18 (c)
Rev. 2

III-16 (c)
Rev. 2

III-10 (c)
Rev. 3

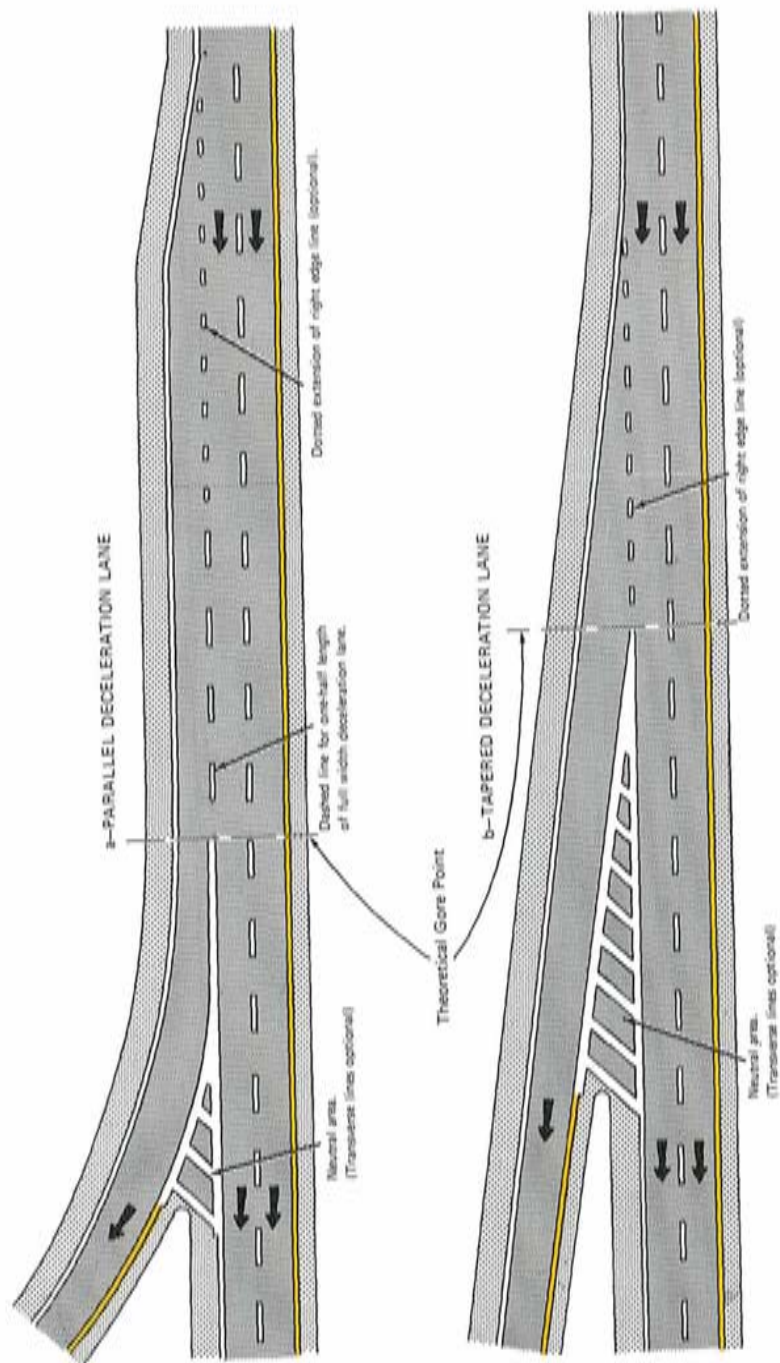

Figure 3-11. Typical exit ramp markings.

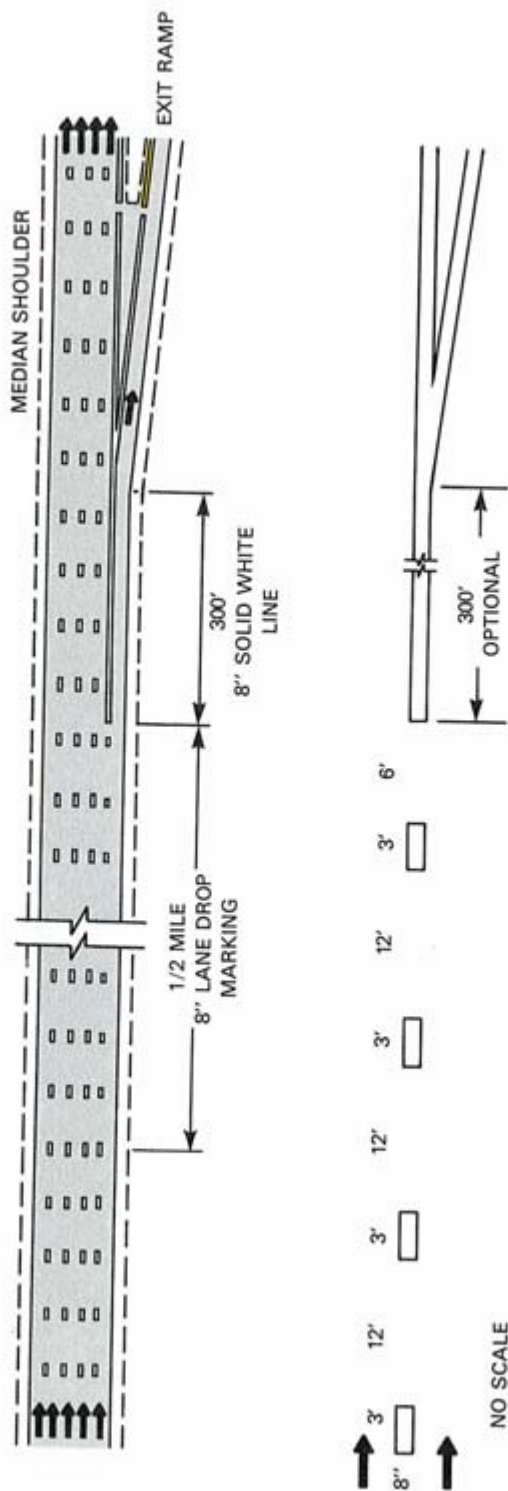

Figure 3-11a. Lane drop markings at exit ramps

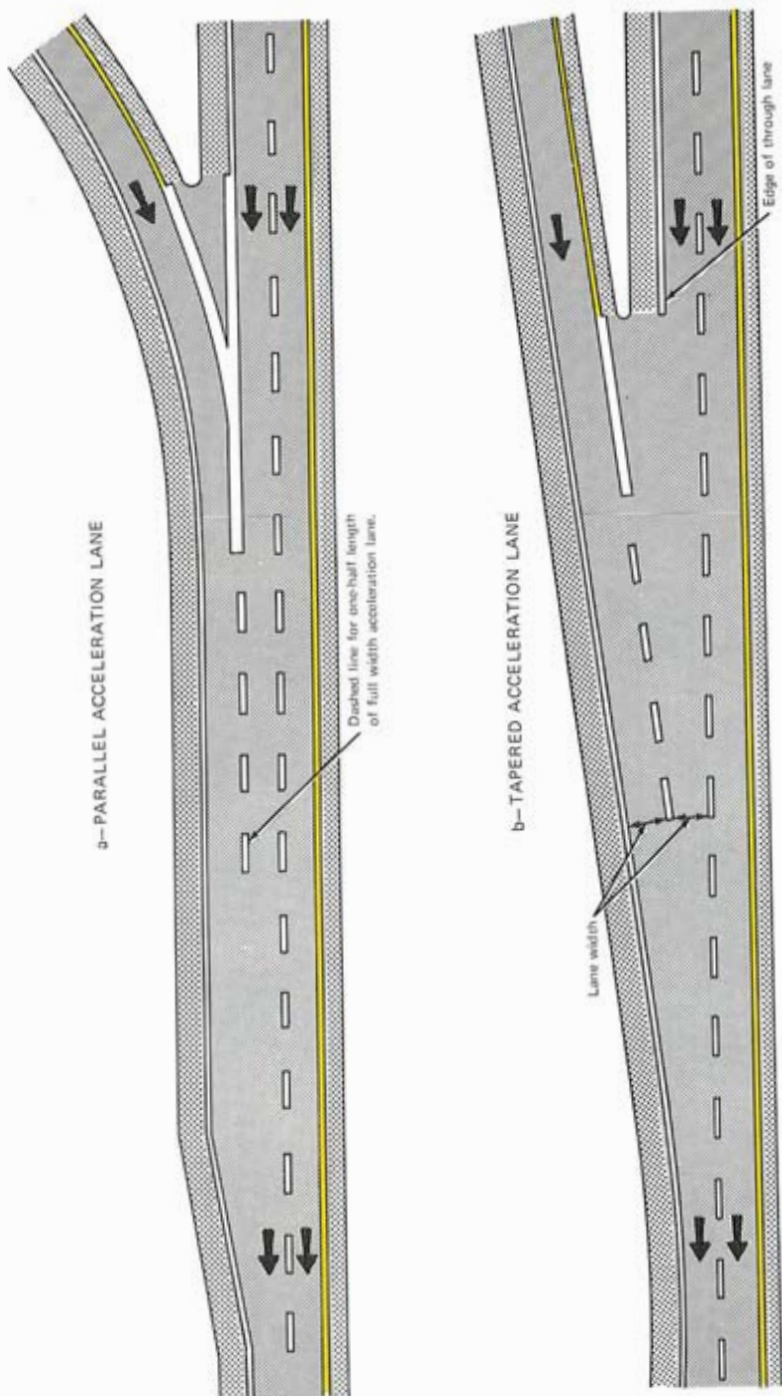

Figure 3-12. Typical entrance ramp markings.

3B-12 Combination Lane and Center Line Markings for Unique Applications

It is sometimes necessary to use markings in certain combinations not previously described for special applications intended to improve traffic operations.

For reversible lane markings, each edge of the lane shall be marked by the use of a double, normal, broken yellow line with the gaps and segments adjacent to one another. Signs and/or signals shall be used to supplement the pavement markings (fig. 3-1, page 3B-3).

A two-way left turn lane is a lane reserved in the center of a highway for exclusive use of left turn vehicles and shall not be used for passing and overtaking or travel by a driver except to make a left turn. The lane may be used by drivers making the left turn in either direction. A two-way left turn lane shall be marked by a single direction, no-passing marking on each edge of the lane and pavement marking arrows as shown in figure 3-5a. This is generally used on a five lane highway where there are two lanes of through traffic in each direction. Signs should be used with the pavement markings (sec. 2B-19).

11-75(c)
Rev. 4

3B-13 Approach to an Obstruction

Pavement markings shall be used to guide traffic on the approach to fixed obstructions within a paved roadway. An obstruction may be so located that all traffic must keep to the right of it, or it may be between two lanes of traffic moving in the same direction. The markings in either case must be designed to guide traffic away from the obstruction. The use of channelizing lines or no-passing markings are generally effective. Obstruction approach markings for bridge supports, refuge islands, median islands, and channelization islands shall consist of a diagonal line, or lines, extending from the center line or the lane line to a point 1 or 2 feet to the right side, or to both sides, of the approach end of the obstruction (fig. 3-13).

The length of the diagonal markings (taper length) should be computed by the formula $L = WS$ for freeways, expressways and all other roadways having a posted speed of 45 m.p.h. or greater. The formula $L = WS^2/60$ should be used to compute taper length on urban, residential, and other streets where the posted speeds are 40 m.p.h. or less. Under both formulas, L equals the taper length in feet, W the width of the offset in feet, and S the off-peak 85 percentile speed in miles per hour. The minimum taper length shall be 100 feet in urban areas and 200 feet in rural areas.

If traffic is required to pass only to the right of the obstruction, the marking shall consist of a no-passing marking at least twice the length of the diagonal portion determined by the applicable taper formula (above). Yellow markings may be placed in the triangular area so formed.

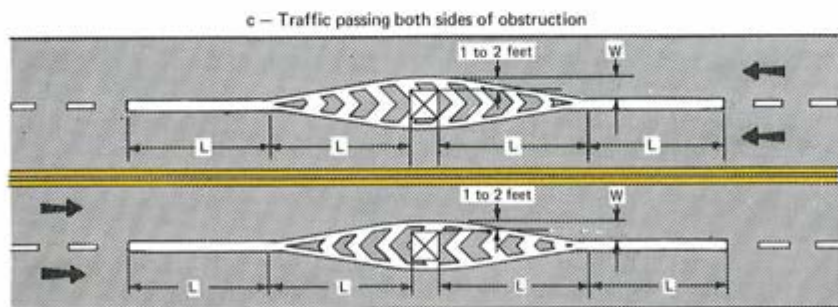
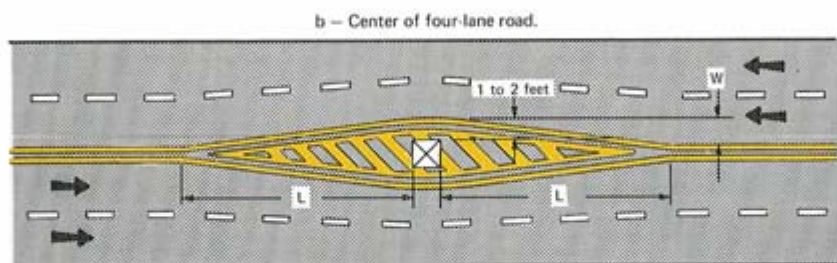
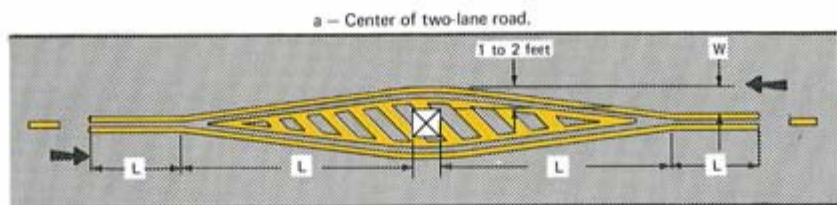

For speeds 45 or more $L = S \times W$ For speeds 40 or less $L = \frac{WS^2}{60}$

S = 85th percentile speed in miles per hour
 W = Offset distance in feet

Minimum length of: L = 100 feet in urban areas
 L = 200 feet in rural areas

Length "L" should be extended as required by sight distance conditions.

Figure 3-13. Typical approach markings for obstructions in the roadway.

If traffic may pass either to right or left of the obstruction, the markings shall consist of two channelizing lines diverging from the lane line, one to either side of the obstruction for a length determined by the applicable taper formula. In advance of the point of divergence, a wide solid white line or double white line shall be extended in place of the broken lane line for a distance equal to the length of the diverging lines. Additional white markings may be placed in the triangular area between the channelizing lines.

3B-14 Pavement Markers as Vehicle Positioning Guides with Other Longitudinal Markings

Raised pavement markers may be used as positioning guides with other longitudinal markings, without necessarily conveying information to the motorist as to passing or lane use restrictions. In such applications, markers may be used, positioned between the two lines of a one-way or two-way no passing zone, or in line with or immediately adjacent to a single solid or broken center line or lane lines. On concrete pavements, the raised markers should be placed to one side of longitudinal joints. A typical spacing for such applications is $2N$. (See Section 3A-10 for definition of N .) Where the driver's attention should be drawn to changes in travel path, such as sharp curves or transitions to reduce the number of lanes or shift traffic laterally, the spacing may be reduced to N , or less.

III-9(c)
Rev. 4

3B-15 Raised Pavement Markers Supplementing Other Markings

Raised pavement markers may be used to supplement other longitudinal markings. Where double lines are to be supplemented, pairs of markers placed laterally in line with, or immediately outside of the two lines, should normally be used. When supplementing wide lines, raised pavement markers may be placed laterally adjacent to each other to simulate the width of the line.

1. Solid lines should be supplemented at a spacing no greater than "N", except left edge lines, which should be supplemented at a spacing no greater than $N/2$. Raised markers generally should not supplement right edge lines.

2. Broken lines should be supplemented at a spacing no greater than $2N$, except those identifying reversible lanes, which should be supplemented at a spacing no greater than "N".

3. Dotted lines should be supplemented with spacing appropriate for the application. Typical spacing for pavement markings through at-grade intersections is one raised marker for each short line segment or "dot". For edge line extensions through freeway interchanges, the typical edge line spacing of $N/2$, may be used.

III-9(c)
Rev. 4

Raised pavement markers may also be used to supplement other markings for channelizing islands or approaches to obstructions. Positioning and

spacing of the markers in such cases must be determined by engineering judgment.

III-9(c)
Rev. 4

3B-16 Substituting for Pavement Markings

Retroflective raised pavement markers, or non-retroflective raised pavement markers supplemented by retroflective markers, may be substituted for markings of other types.

The pattern of the raised markers should simulate the pattern of the markings for which they are substituted.

The normal spacing of raised pavement markers, when substituting for painted markers, should be chosen in relationship to the standard length of the broken line segment.

Broken line segments may be substituted by a group of four or five markers equally spaced at approximately $N/12$ feet, or at approximately the third point of the line segment if N is other than 40 feet, with at least one of every group of markers retroreflective.

III-9(c)
Rev. 4

Solid lines may be substituted for at a spacing of approximately $N/8$ feet, with retroreflective units at a spacing no greater than $N/2$.

Dotted lines shall be substituted for at a spacing of approximately $N/8$ feet, but with not less than one raised pavement marker per dotted line. At least one raised marker every N feet shall be retroreflective.

When substituting for wide lines, raised pavement markers may be placed laterally adjacent to simulate the width of the line.

3B-17 Stop Lines

III-9(c)
Rev. 4

Stop lines are solid white lines, normally 12 to 24 inches wide, extending across all approach lanes.

Stop lines should be used in both rural and urban areas where it is important to indicate the point, behind which vehicles are required to stop, in compliance with a STOP sign, traffic signal, officers' direction, or other legal requirement.

Stop lines, where used, should ordinarily be placed 4 feet in advance of and parallel to the nearest crosswalk line. In the absence of a marked crosswalk, the Stop line should be placed at the desired stopping point, in no case more than 30 feet or less than 4 feet from the nearest edge of the intersecting roadway.

If a stop line is used in conjunction with a STOP sign, it should ordinarily be placed in line with the STOP sign. However, if the sign cannot be located exactly where vehicles are expected to stop, the Stop line should be placed at the stopping point.

3B-18 Crosswalks and Crosswalk Lines

III-9(c)
Rev. 4

Crosswalk markings at signalized intersections and across intersectional approaches on which traffic stops, serve primarily to guide pedestrians in

the proper paths. Crosswalk markings across roadways on which traffic is not controlled by traffic signals or STOP signs, must also serve to warn the motorist of a pedestrian crossing point. At non-intersectional locations, these markings legally establish the crosswalk.

Crosswalk lines shall be solid white lines, marking both edges of the crosswalk. They shall be not less than 6 inches in width and should not be spaced less than 6 feet apart. Under special circumstances where a stop line is not provided or where vehicular speeds exceed 35 MPH or where crosswalks are unexpected, it may be desirable to increase the width of the crosswalk line up to 24" in width. Crosswalk lines on both sides of the crosswalk should extend across the full width of pavement to discourage diagonal walking between crosswalks (fig. 3-14a).

Crosswalks should be marked at all intersections where there is substantial conflict between vehicle and pedestrian movements. Marked crosswalks should also be provided at other appropriate points of pedestrian concentration, such as at loading islands, midblock pedestrian crossing, or where pedestrians could not otherwise recognize the proper place to cross.

Crosswalk markings should not be used indiscriminately. An engineering study should be required before they are installed at locations away from traffic signals or STOP signs.

Since non-intersectional pedestrian crossings are generally unexpected by the motorist, warning signs (sec. 2C-31) should be installed and adequate visibility provided by parking prohibitions.

For added visibility, the area of the crosswalk may be marked with white diagonal lines at a 45° angle or with white longitudinal lines at a 90° angle to the line of the crosswalk (figs. 3-14b, 14c). These lines should be approximately 12" to 24" wide and spaced 12" to 24" apart. When diagonal or longitudinal lines are used to mark a crosswalk, the transverse crosswalk lines may be omitted. This type of marking is intended for use at locations where substantial numbers of pedestrians cross without any other traffic control device, at locations where physical conditions are such that added visibility of the crosswalk is desired or at places where a pedestrian crosswalk might not be expected. Care should be taken to insure that crosswalks with diagonal or longitudinal lines used at some locations do not weaken or detract from other crosswalks (where special emphasis markings are not used) (fig. 3-14a). When an exclusive pedestrian phase signal, which permits diagonal crossing, is installed at an intersection, a unique marking may be used for the crosswalk (fig. 3-15).

3B-19 Parking Space Markings

Parking space markings shall be white.

The marking of parking space limits on urban streets encourages more orderly and efficient use of parking spaces where parking turnover is

a – Standard crosswalk marking.

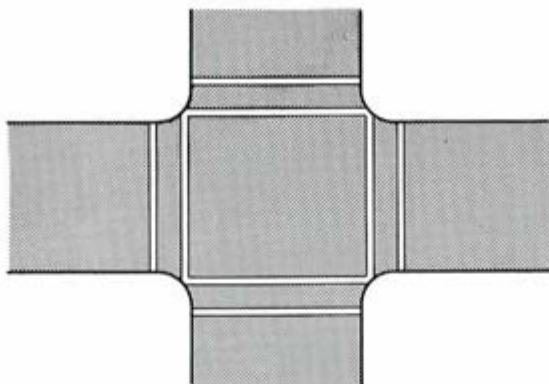

b – Crosswalk marking with diagonal lines for added visibility.

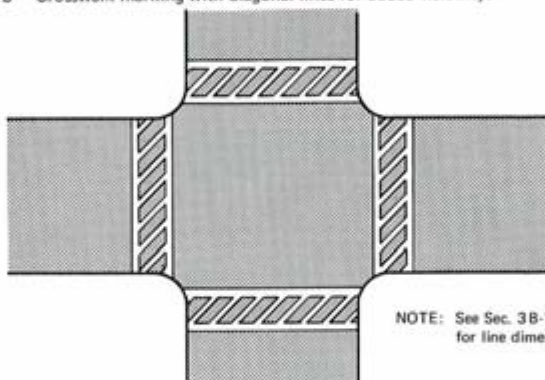

NOTE: See Sec. 3B-15
for line dimensions

c – Crosswalk marking with longitudinal lines for added visibility.

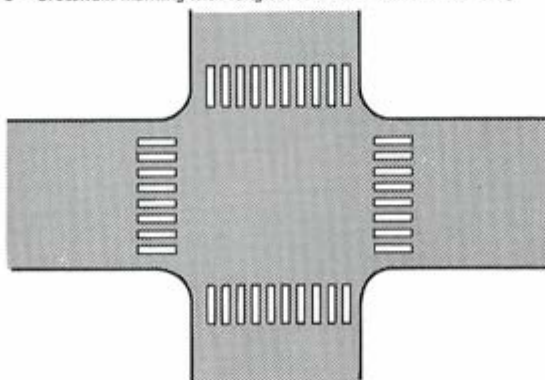
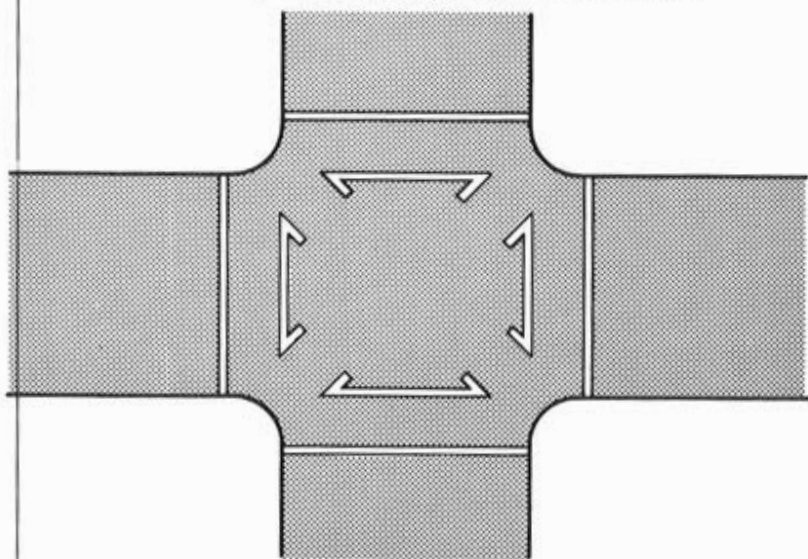

Figure 3-14. Typical crosswalk markings.

a – Crosswalk marking that outlines pedestrian travel paths.



b – Crosswalk marking that outlines the edge of pedestrian travel area.

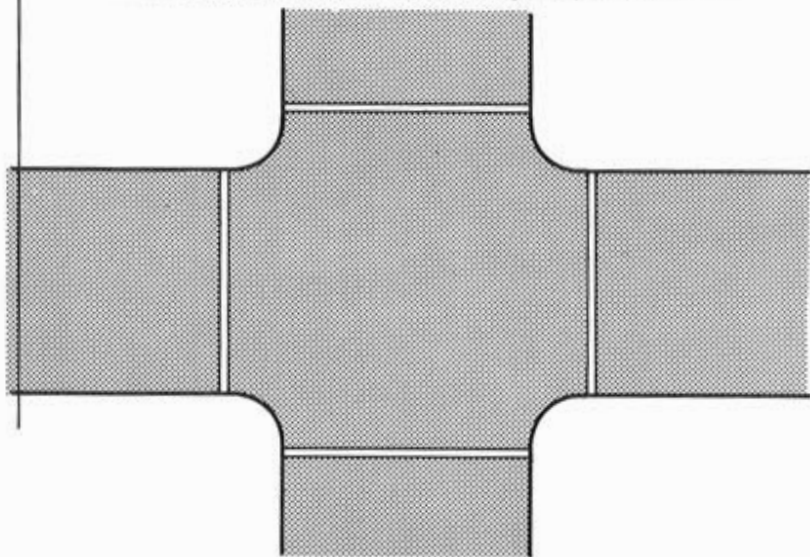

Figure 3-15. Typical crosswalk marking for exclusive pedestrian phase.

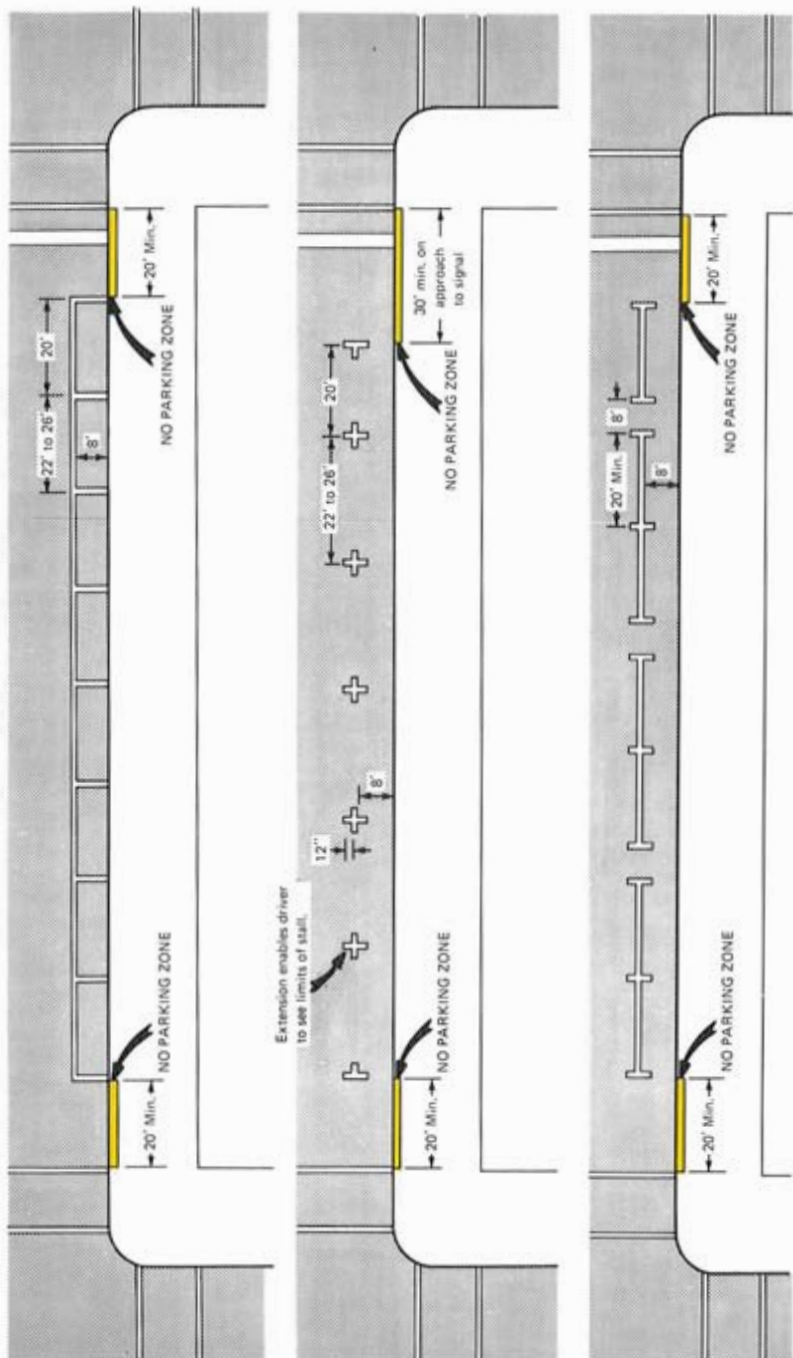

Figure 3-16. Typical parking-space limit markings.

substantial and tends to prevent encroachment on fire hydrant zones, bus stops, loading zones, approaches to corners, clearance spaces for islands and other zones where parking is prohibited. Typical parking space markings are shown in figure 3-16.

3B-20 Pavement Word and Symbol Markings

III-9(c)
Rev. 4

Word and symbol markings on the pavement may be used for the purpose of guiding, warning, or regulating traffic. They should be limited to not more than a total of three lines of information. They shall be white in color.

Symbol arrows may be used to convey either guidance or mandatory messages; however, where a movement that would otherwise be legal is to be prohibited, the arrow marking must be accompanied by standard signs and the word marking "ONLY." Signs or markings should be repeated in advance of mandatory turn lanes when necessary to prevent entrapment and to help motorists select the appropriate lane before reaching the end of the line of waiting vehicles.

All letters, numerals and symbols should be in conformance with the Standard Alphabets for Highway Signs and Pavement Markings.* Large letters and numerals should be used, 8 feet or more in height; and, if the message consists of more than one word, it should read "up," i.e., the first word should be nearest to the driver. Symbol messages are generally preferable to word messages.

Where speeds are low, somewhat smaller characters may be used. The space between lines should be at least four times the height of the characters for low speed roads but not more than ten times the height of the characters, under any conditions. Examples are shown in figures 3-17 and 3-18.

Word and symbol markings considered appropriate for use when warranted include the following:

1. Regulatory:

"STOP"

"RIGHT (LEFT) TURN ONLY"

"25 MPH"

"SYMBOL ARROWS"

(Note: Symbol arrows shall be supplemented by word "ONLY," if mandatory.)

2. Warning:

"STOP AHEAD"

"SIGNAL AHEAD"

"SCHOOL"

"SCHOOL X-ING"

"PED X-ING"

"R X R"

(Railroad Crossing)

(secs. 8B-2, 8B-3)

* Available from the Federal Highway Administration (HTO-20), Washington, D.C. 20590.

3. Guide:

"US 40"

"ROUTE 40"

"STATE 135" (Other words or symbols may be necessary under certain conditions.)

Since an uncontrolled use of pavement markings can result in driver confusion the number of different word and symbol markings should be minimized.



Figure 3-17. Elongated letters for pavement marking.

The word "STOP" shall not be used on the pavement unless accompanied by a stop line (sec. 3B-14) and STOP sign (sec. 2B-4).

The word STOP shall not be placed on the pavement in advance of a stop line, unless every vehicle is required to stop at all times.

Pavement messages should generally be no more than one lane in width except the "SCHOOL" messages (sec. 7C-6).

Figure 3-19 shows the use of word and symbol markings on the pavement.

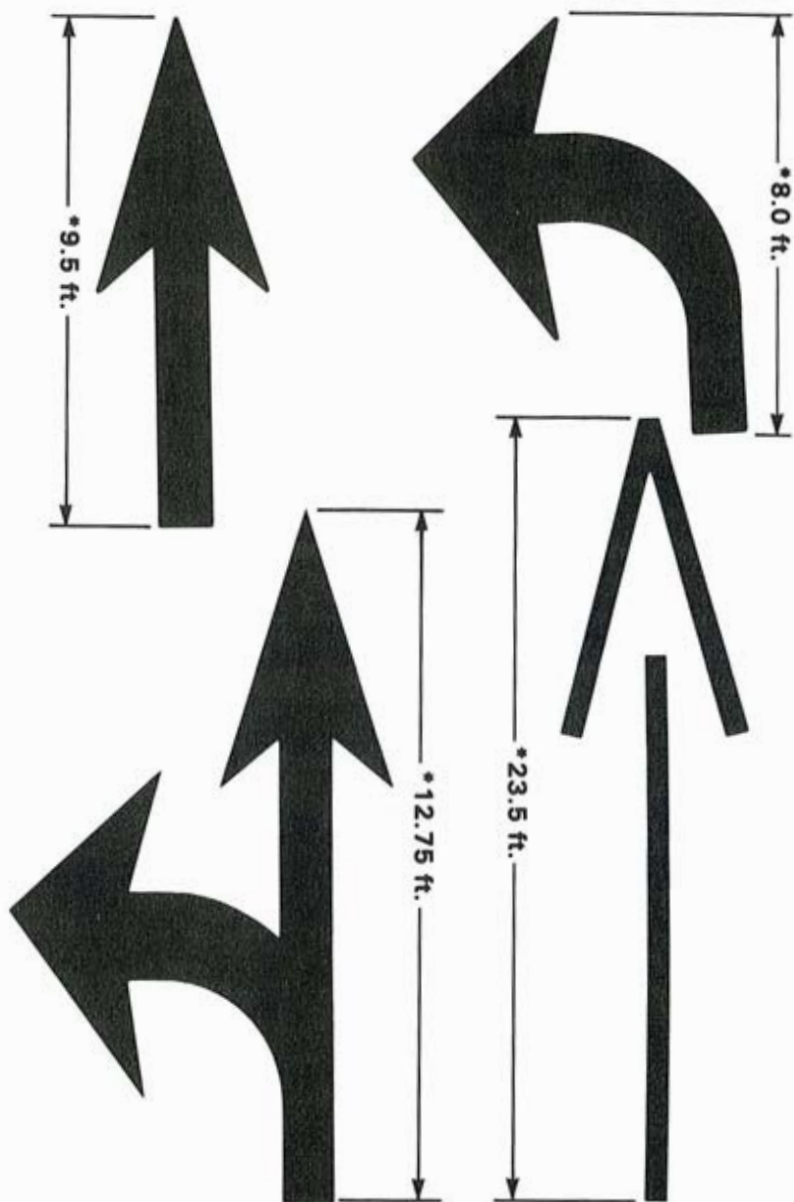

- * Minimum sizes for normal installation; larger sizes may be needed for freeways, above average speeds, and other critical conditions. For proper proportion, see Standard Alphabets for Highway Signs and Pavement Markings (available from FHWA, HTO-20, Washington, D.C. 20590).

Figure 3-18. Elongated arrows for pavement markings.

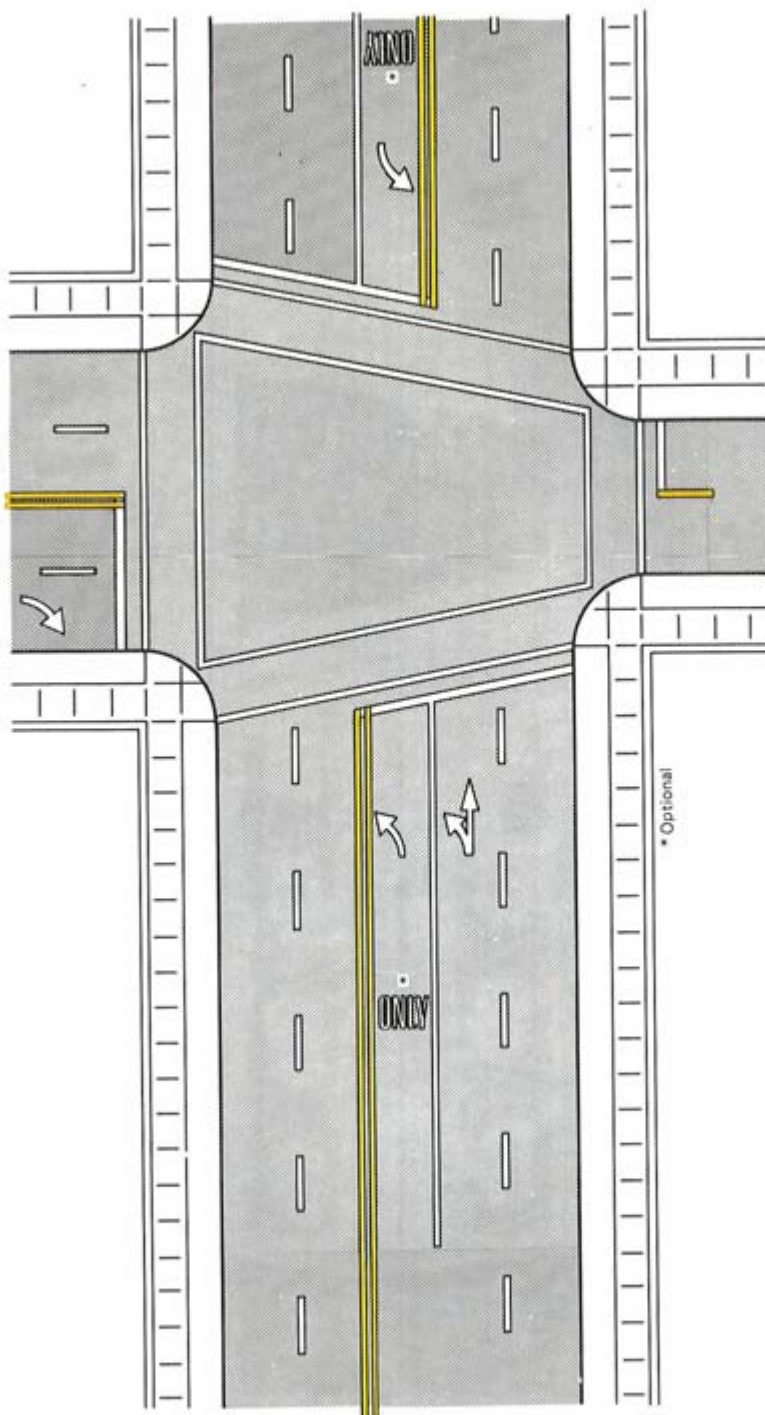

Figure 3-19. Typical lane-use-control word and symbol markings.

3B-21 Curb Markings for Parking Restrictions

III-9(c)
Rev

Since curb markings of yellow and white are used for delineation and visibility, it is usually advisable to establish parking regulations through the installation of standard signs (secs. 2B-31 to 33). However, when local authorities prescribe special colors for curb markings as supplemental to standard signs, they may be used.

When signs are not used, intended meaning should be stenciled on the curb.

Signs shall always be used with curb markings in those areas where curb markings are frequently obliterated by accumulations of snow and ice.

3B-22 Preferential Lane Markings

III-9(c)
Rev. 4

When a lane is assigned full or part time to a particular class or classes of vehicles, the preferential lane markings shall be used.

The marking is intended to convey that a restriction on the class or classes of vehicles permitted to use the lane exists, and it is supplemental to signs or signals conveying the specific restrictions. Signs or signals shall be used with the preferential lane markings.

The preferential lane marking shall be the elongated diamond detailed in the Standard Alphabets for Highway Signs and Pavement Markings.* The diamond shall be formed by white lines at least 6 inches in width, shall be at least 2 ½ feet in width and 12 feet long and shall be placed coincident with the longitudinal center of each restricted lane.

The frequency with which the marking is placed is a matter for engineering judgment based on prevailing speed, block lengths, distance from intersections, and other considerations necessary to adequately communicate with the driver. Spacing as close as 80 feet may be appropriate for a city street, while a spacing of 1000 feet may be appropriate for a freeway.

Word markings may be used to supplement but not substitute for the preferential lane markings.

3B-23 Speed Measurement Markings

III-9(c)
Rev. 4

A speed measurement marking is a transverse marking placed on the roadway for the purpose of assisting in the enforcement of speed regulations. Speed measurement markings, if used, shall be white, and shall be not greater than 24 inches wide. They may extend approximately 2 feet on either side of the centerline or edgeline of the paved surface at ¼ mile intervals over a 1-mile length of roadway. Advisory signs may be used in conjunction with these markings.

* Available from FHWA (HTO-20), Washington, D.C. 20590.

C. OBJECT MARKINGS

3C-1 Object Marker Design

Object markers are used to mark obstructions within or adjacent to the roadway. When used, these markers shall consist of an arrangement of one or more of the following designs:

Type 1—Either a marker consisting of nine yellow reflectors, each with a minimum dimension of approximately 3", mounted symmetrically on an 18" yellow or black diamond panel; or an all yellow reflective diamond panel of the same size. Type 1 markers may be larger if conditions warrant.

Type 2—Either a marker consisting of three yellow reflectors, each with a minimum dimension of approximately 3", arranged either horizontally or vertically; or an all yellow reflective panel, 6" × 12". Type 2 markers may be larger if conditions warrant.

Type 3—Striped marker consisting of a vertical rectangle approximately 1 foot by 3 feet in size with alternating black and reflectorized yellow stripes sloping downward at an angle of 45° toward the side of the obstruction on which traffic is to pass. The minimum width of the yellow stripe shall be 3 inches. A better appearance can be achieved if the black stripes are wider than the yellow stripes.

III-7 (c)
Rev. 2

Type 3 object markers with stripes which begin at the upper right side and slope downward to the lower left side are to be designated as "right" object markers (OM-3R). Object markers with stripes which begin at the upper left side and slope downward to the lower right side are to be designated as "left" object markers (OM-3L).

3C-1.1 Mounting Height

When used for marking objects in the roadway or 8 feet or less from the shoulder or curb, the mounting height to the bottom of the object marker should normally be 4 feet above the surface of the nearest traffic lane. When used to mark objects more than 8 feet from the shoulder or curb, the mounting height to the bottom of the object marker may be 4 feet above the ground.

III-23 (c)
Rev. 3

When object markers or markings are applied to a hazardous object which by its nature requires a lower or higher mounting, the vertical mounting height may vary according to need.

3C-2 Objects in the Roadway

Obstructions within the roadway, shall be marked with a Type 1 or Type 3 object marker.

For additional emphasis, a large surface such as a bridge pier may be painted with diagonal stripes, 12 inches or greater in width, similar in design to the Type 3 object marker. The alternating black and reflectorized yellow stripes shall be sloped down at an angle of 45° toward the side of the obstruction which traffic is to pass.

III-7 (c)
Rev. 2
III-23 (c)
Rev. 3

Appropriate signs (secs. 2B-25 and 2C-33) directing traffic to one or both sides of the obstruction may be used in lieu of the object marker. In addition to markings on the face of an obstruction in the roadway, warning of approach to the obstruction shall be given by appropriate pavement markings (sec. 3B-13).

Where the vertical clearance of an overhead structure exceeds the maximum legal height of vehicle by less than one foot, the clearance in feet and inches should be clearly marked on the structure (sec. 2C-34).

3C-3 Objects Adjacent to the Roadway

Objects not actually in the roadway may be so close to the edge of the road that they need a marker. These include underpass piers, bridge abutments, handrails and culvert headwalls. In some cases there may not be a physical object involved, but other roadside conditions such as narrow shoulder drop-offs, gores, small islands and abrupt changes in the roadway alignment may make it undesirable for a driver to leave the roadway. Type 2 or 3 object markers are intended for use at such locations. The inside edge of the marker shall be in line with the inner edge of the obstruction.

Standard warning signs (Part II-C) should also be used where applicable. Typical applications of markers for roadside obstructions are shown in figure 3-20.

3C-4 End of Roadway

When it is determined that markers should be placed at the end of a roadway where there is no alternate vehicular path, either a marker consisting of nine red reflectors, each with a minimum dimension of approximately 3", mounted symmetrically on an 18-inch diamond, red or black panel; or an 18-inch diamond reflectorized red panel shall be used. More than one marker or a larger marker may be used at the end of the roadway where conditions warrant. The minimum mounting height of this marker shall be four feet. Appropriate advance warning signs should be used.

Editorial
Change
Rev. 2

Editorial
Change
Rev. 2

Typical Type 1 Object Markers



18"x18"



18"x18"



18"x18"

Typical Type 2 Object Markers



6"x12"



6"x12"



12"x6"



12"x6"

Typical Type 3 Object Markers



OM-3L
12"x36"



OM-3R
12"x36"

Typical End of Road Markers



18"x18"



18"x18"



18"x18"

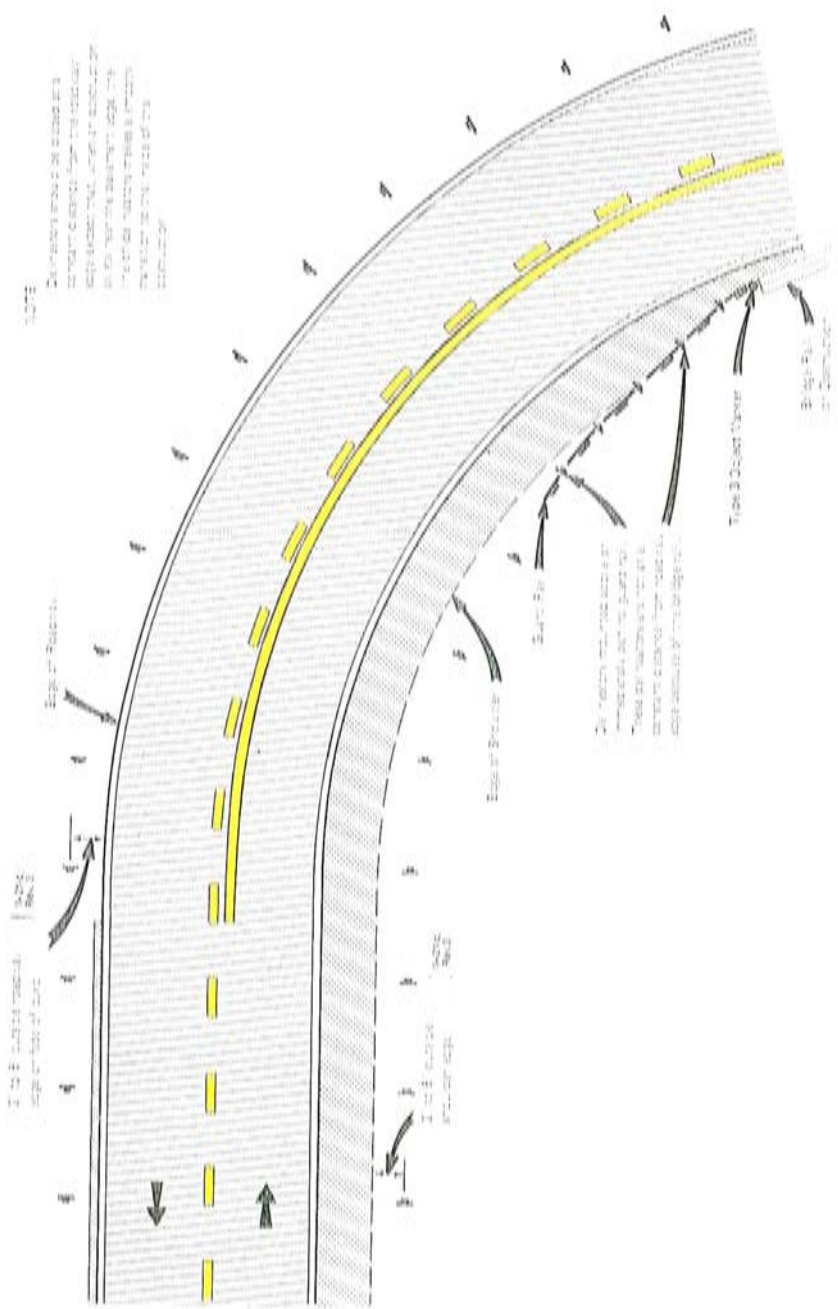

Figure 3-20. Typical delineator installation.

D. DELINEATION

3D-1 Delineators

Road delineators are light-retroreflecting devices mounted at the side of the roadway, in series, to indicate the roadway alignment. Delineators are effective aids for night driving and are to be considered as guidance devices rather than warning devices. Delineators may be used on long continuous sections of highway or through short stretches where there are changes in horizontal alignment, particularly where the alignment might be confusing, or at pavement width transitions. An important advantage of delineators, in certain areas, is that they remain visible when the roadway is wet or snow-covered.

3D-2 Design

Delineators shall consist of reflector units capable of clearly reflecting light under normal atmospheric conditions from a distance of 1,000 feet when illuminated by the upper beam of standard automobile lights. Reflective elements for delineators shall have a minimum dimension of approximately 3 inches. Elongated reflective units of appropriate size may be used in place of two reflectors mounted as a unit.

3D-3 Curb Markings for Delineation

Reflectorized solid yellow should be placed on the curbs of islands located in the line of traffic flow where the curb serves to channel traffic to the right of the obstruction. Reflectorized solid white should be used when traffic may pass on either side of the island.

Where the curbs of the islands become parallel to the direction of traffic flow it is not necessary to mark the curbs unless a study indicates the need for this type of delineation. Where these curbs are marked, the colors shall conform to the general principles of markings (sec. 3A-5).

Curbs at openings in a continuous median island need not be marked unless individual study indicates the need for this type of marking.

3D-4 Delineator Application

Delineation is intended to be a guide to the vehicle operator as to the alignment of the highway; whatever is needed to provide that guidance in a clear and simple way should be installed.

The color of delineators shall, in all cases, conform to the color of edgelines stipulated in section 3B-6.

Single delineators shall be provided on the right side of expressway and freeway roadways and on at least one side of interchange ramps. They may be provided on other classes of roads.

Single delineators may be provided on the left side of roadways and should be provided on the outside of curves on interchange ramps.

Where median crossovers are provided for official or emergency use on divided highways and where these crossovers are to be marked, a double yellow delineator should be placed on the left side of the through roadway on the far side of the crossover for each roadway.

Double or vertically elongated delineators should be installed at 100-foot intervals along acceleration and deceleration lanes.

Red delineators may be used on the reverse side of any delineator whenever it would be viewed by a motorist traveling in the wrong direction on that particular ramp or roadway.

Delineators of the appropriate color may be used to indicate the narrowing of the pavement where either an outside or inside lane merges into an adjacent lane. The delineators should be used adjacent to the lane affected for the full length of the convergence and should be so placed and spaced to show the width reduction (fig. 3-10, page 3B-13). Delineation is not necessary for the traffic moving in the direction of a wider pavement or on the side of the roadway where the alignment is not affected by the convergence. On a highway with continuous delineation on either or both sides, delineators should be carried through the transition and a closer spacing may be warranted.

Delineation shall be optional on sections of roadway between interchanges where fixed-source lighting is in operation.

When used, delineators shall be red in color and should normally be placed on both sides of truck escape ramps. The delineators should be spaced at 50 feet intervals for a distance sufficient to identify the ramp entrance. Delineator spacing beyond the ramp entrance should be adequate for guidance in accordance with the length and design of the escape ramp.

III-24 (c)
Rev. 3

3D-5 Delineator Placement and Spacing

Delineators, if used, shall be mounted on suitable supports so that the top of the reflecting head is about 4 feet above the near roadway edge. They shall be placed not less than 2 or more than 8 feet outside the outer edge of the shoulder, or if appropriate, in the line of the roadside barrier that is 8 feet or less outside the outer edge of the shoulder.

III-21 (c)
Rev. 3
Editorial
Change
Rev. 4

Delineators should be placed at a constant distance from the edge of the roadway except that, where a guardrail or other obstruction intrudes into the space between the pavement edge and the extension of the line of delineators, the delineators should be in line with or inside the innermost

edge of the obstruction. Typical delineator installations are shown in figure 3-20 (page 3C-4).

Normally, delineators should be spaced 200 to 528 feet. When normal uniform spacing is interrupted by driveways, cross roads, etc., delineators falling within such areas may be moved in either direction, a distance not exceeding one-quarter of the normal spacing. Delineators still falling within such areas should be eliminated.

Spacing should be adjusted on approaches and throughout horizontal curves so that several delineators are always visible to the driver. Table III-1 shows suggested spacing for delineators at horizontal curves.

Table III-1 Suggested Spacing for Highway Delineators
on Horizontal Curves

(Distance in Feet Rounded to the Nearest 5 Feet)

Radius of Curve (in feet)	Spacing on Curve (in feet) (S)
50	20
150	30
200	35
250	40
300	50
400	55
500	65
600	70
700	75
800	80
900	85
1,000	90

Spacing for specific radii not shown may be interpolated from table. The minimum spacing should be 20 feet. The spacing on curves should not exceed 300 feet. In advance of or beyond a curve, and proceeding away from the end of the curve, the spacing of the first delineator is 2S, the second 3S, and the third 6S but not to exceed 300 feet. S refers to the delineator spacing for specific radii computed from the formula $S = 3 \sqrt{R-50}$.

E. COLORED PAVEMENTS

3E-1 Colored Pavements

When used for guidance and regulation of traffic, colored pavement surfaces are traffic control devices. Situations occur where colored pavements could supplement other traffic control devices. They should be used only where they contrast significantly with adjoining paved areas. Where colored pavements are used, the guidance or control provided shall be applicable at all times.

3E-2 Colors

The use of the following colors for pavements shall be limited to the purposes noted:

1. Red shall be used only on the approaches to a STOP sign which is in use 24 hours a day. The length of colored surface should be related to the 85-percentile approach speed of traffic and give the driver a two to four second advance warning.

2. Yellow shall be used only for medians separating traffic flows in opposite directions.

3. White shall be used for delineation on shoulders, on channelizing islands where traffic passes on both sides in the same general direction, and for crosswalks.

F. BARRICADES AND CHANNELIZING DEVICES

3F-1 Barricades

Red and white barricades are to warn and alert drivers of the terminous of a road, street or highway in other than construction or maintenance areas. The barricades are to meet the design criteria of section 6C-8 for a Type III barricade, except the colors of the stripes shall be reflectorized white and reflectorized red. These devices may be used to mark any of the following type locations:

1. Roadway ends in a dead end or cul-de-sac with no outlet.
2. A ramp or lane closed for operational purposes.
3. The permanent or semipermanent closure or termination of a roadway.

3F-2 Channelizing Devices

Traffic cones and tubular markers are sometimes used outside of construction and maintenance areas for general traffic control purposes. Such uses include adding emphasis to reversible lane delineation, channelizing lines or islands.

These devices shall be a minimum of 18 inches in height and made of materials to withstand impact without damage to themselves or to vehicles. Large size devices should be used wherever more conspicuous guidance is needed.

The color of cones and tube markers used outside construction and maintenance areas shall be the same as the pavement marking which they supplement or for which they are substituted. They should be kept clean and bright for maximum target value. For nighttime use they shall be reflectorized.

Reflectorization of tubular markers shall be a minimum of two three-inch bands placed a maximum of 2" from the top with a maximum of 6" between the bands. Reflectorization of cones shall be provided by a minimum 6" band placed a maximum of 3" from the top. Reflectorized material shall have a smooth, sealed outer surface which will display the same approximate color day and night.

